

ELEVATION.

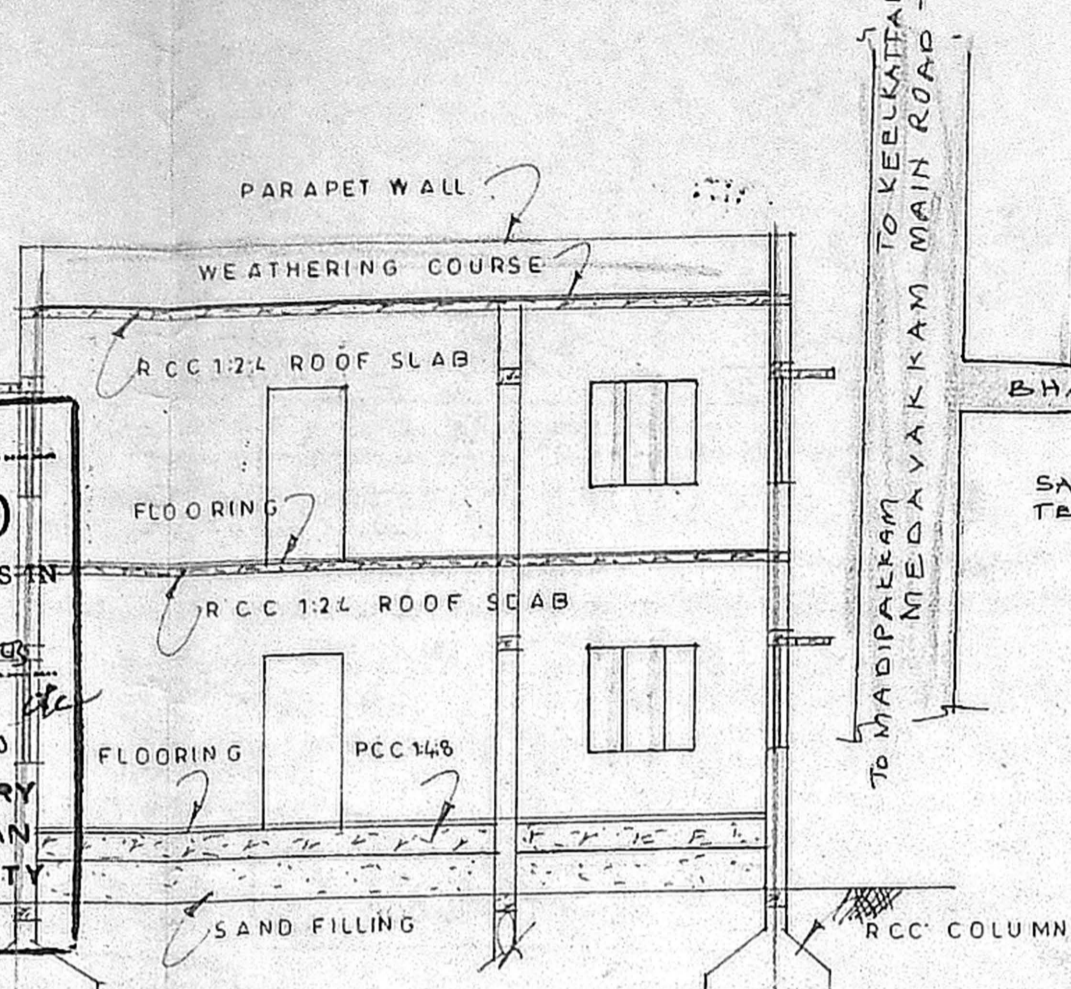

SECTION ON AB

KEY PLAN.

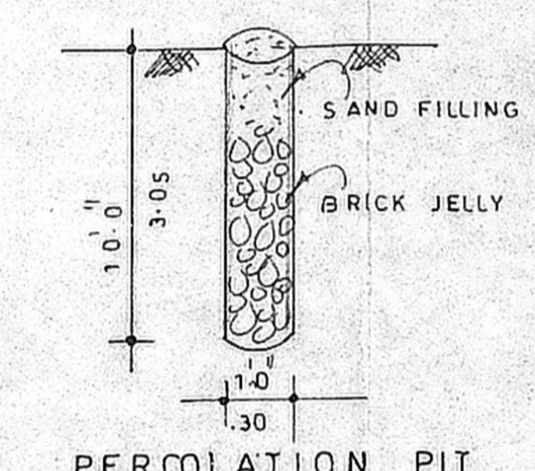

PERCOLATION PIT

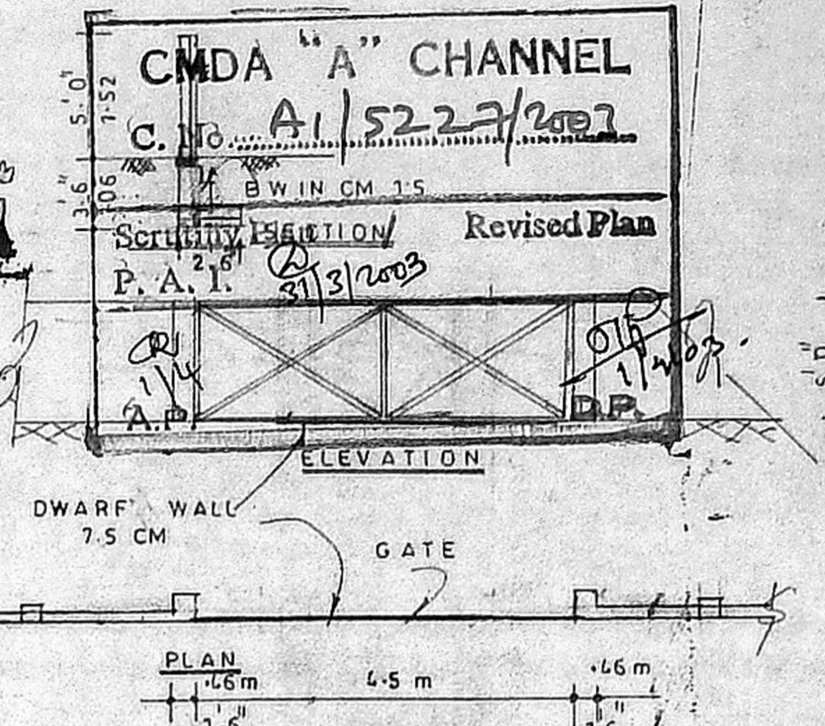

DETAILS OF COMPOUND WALL

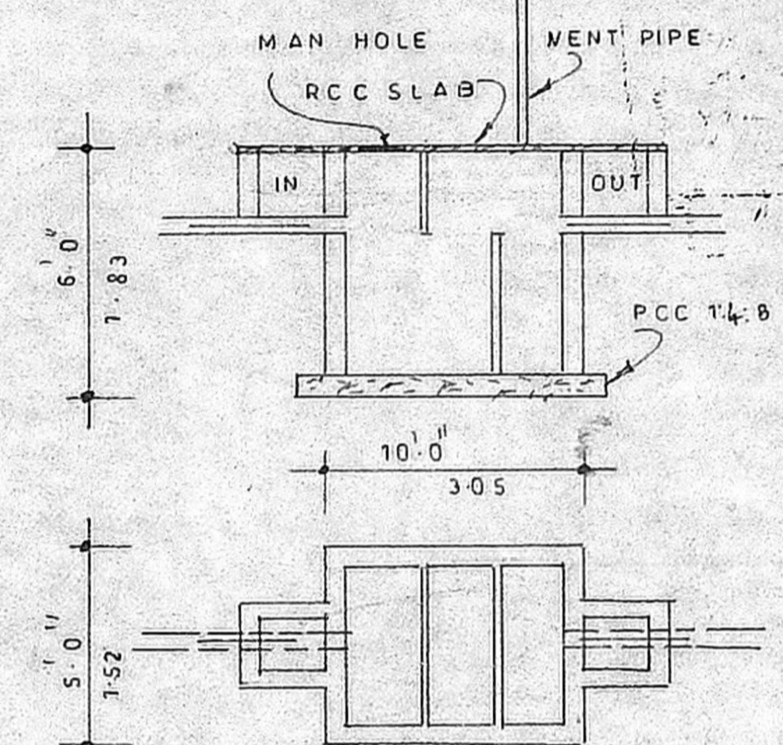

DETAILS OF SEPTIC TANK

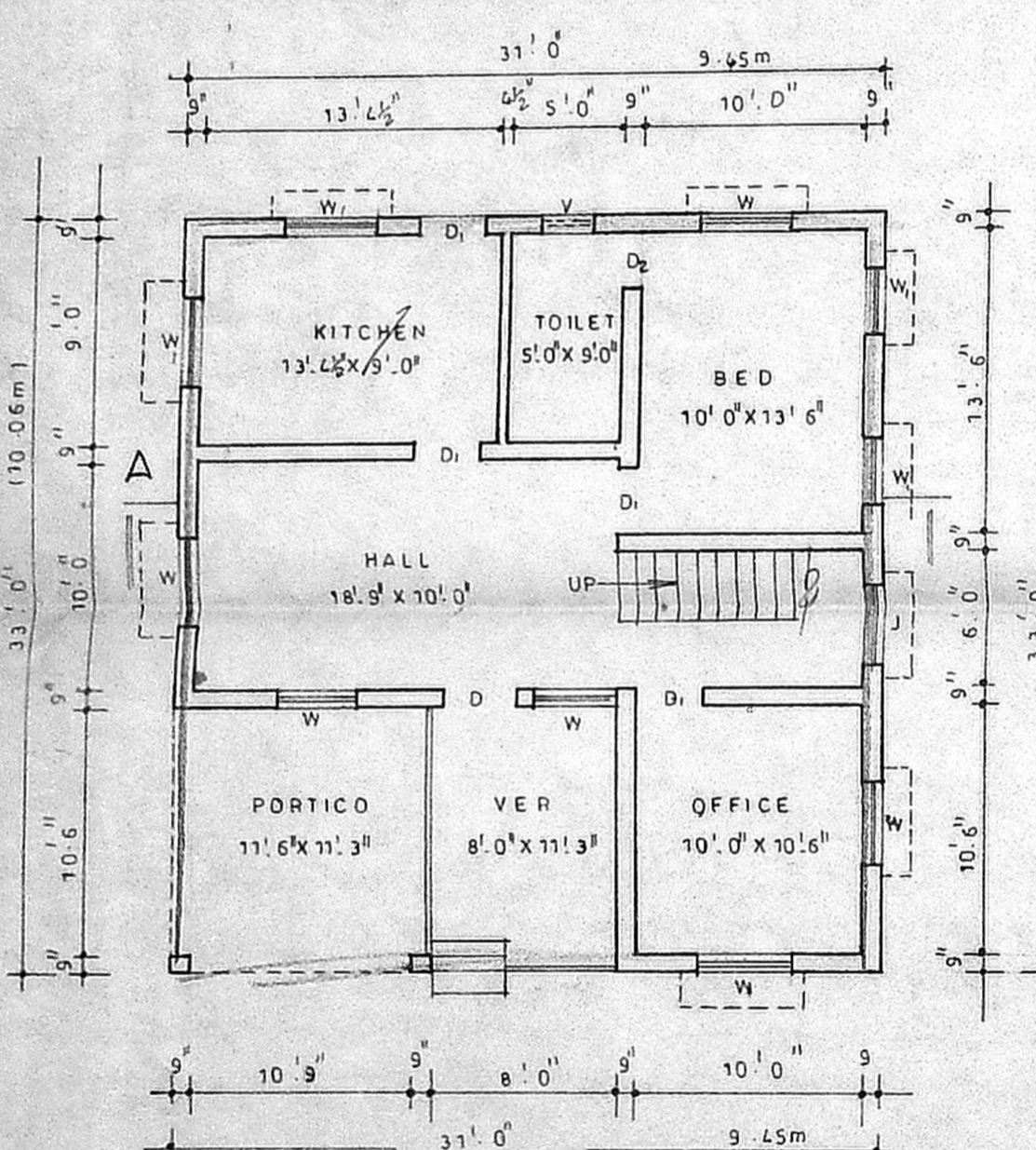

GROUND FLOOR PLAN

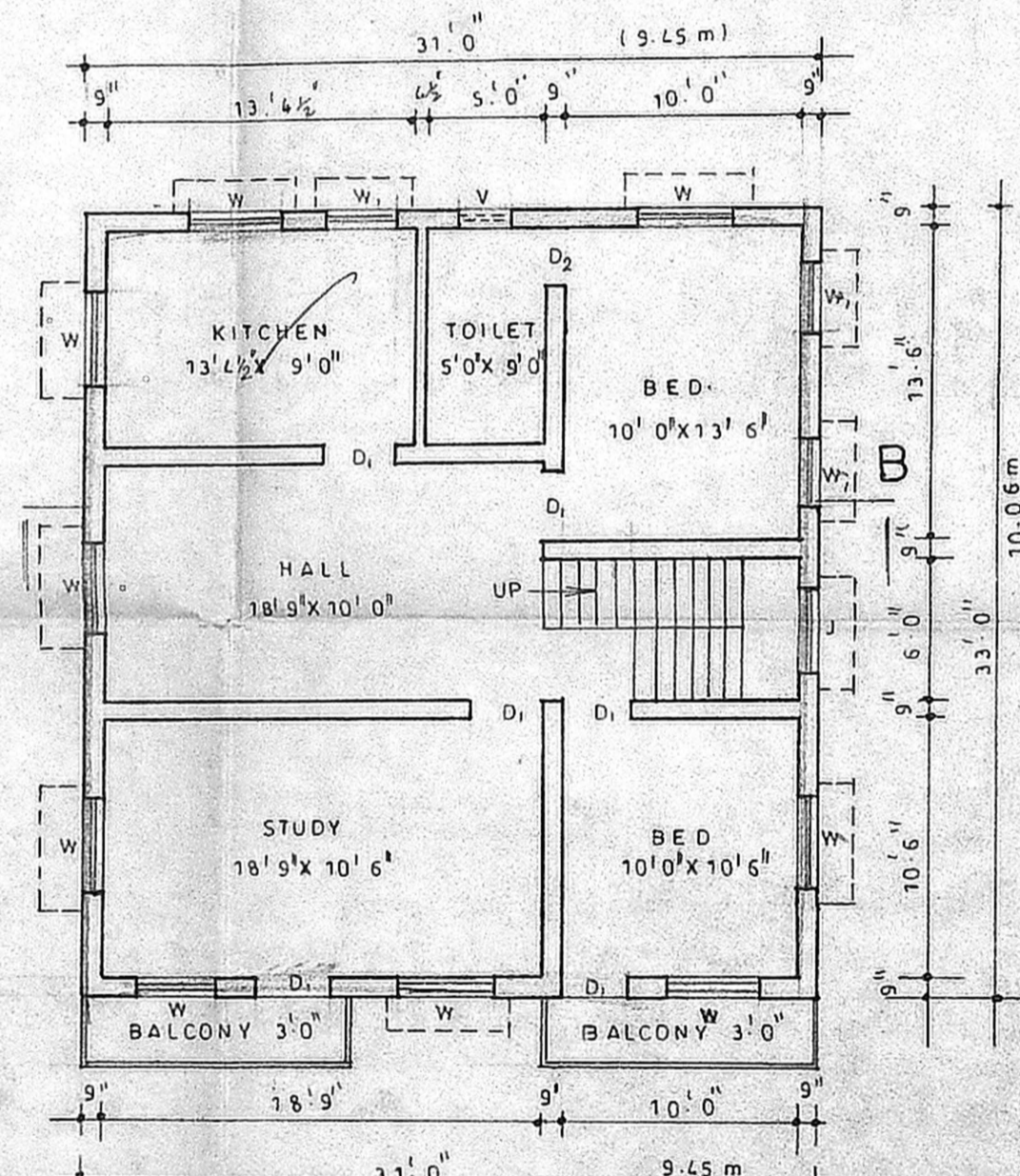

FIRST FLOOR PLAN SCALE 1"=8'0" (1:100)

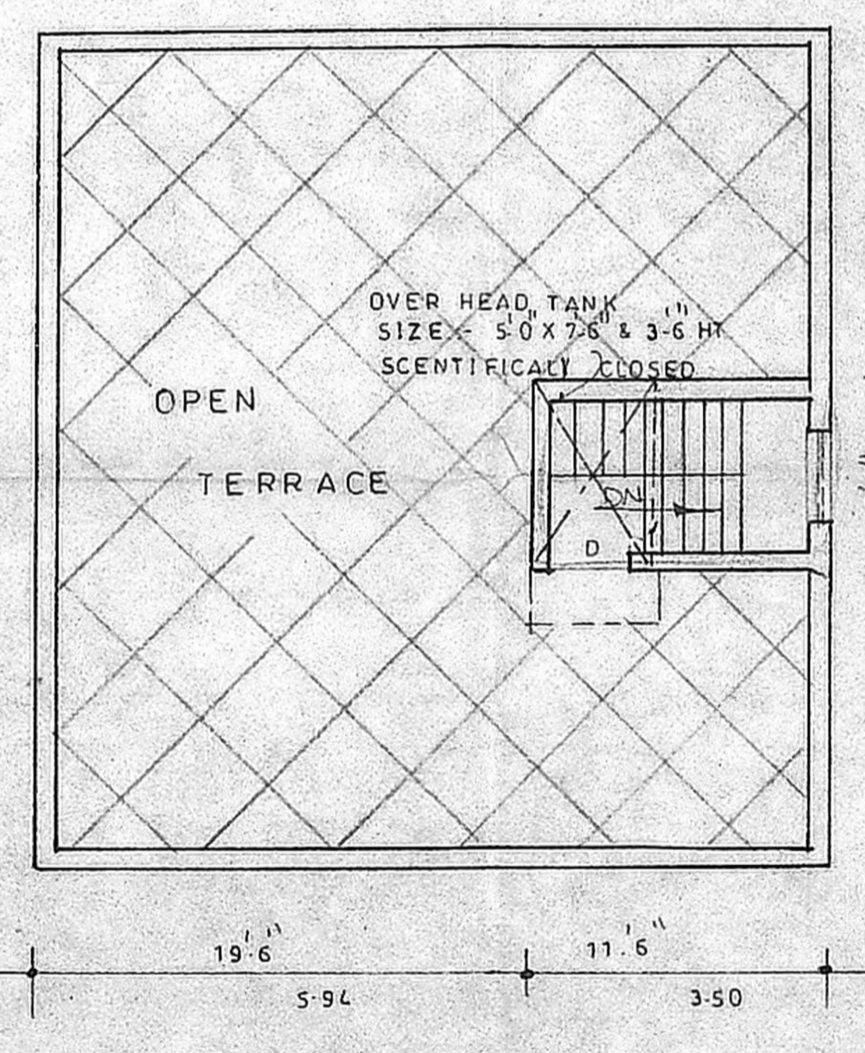

TERRACE FLOOR PLAN

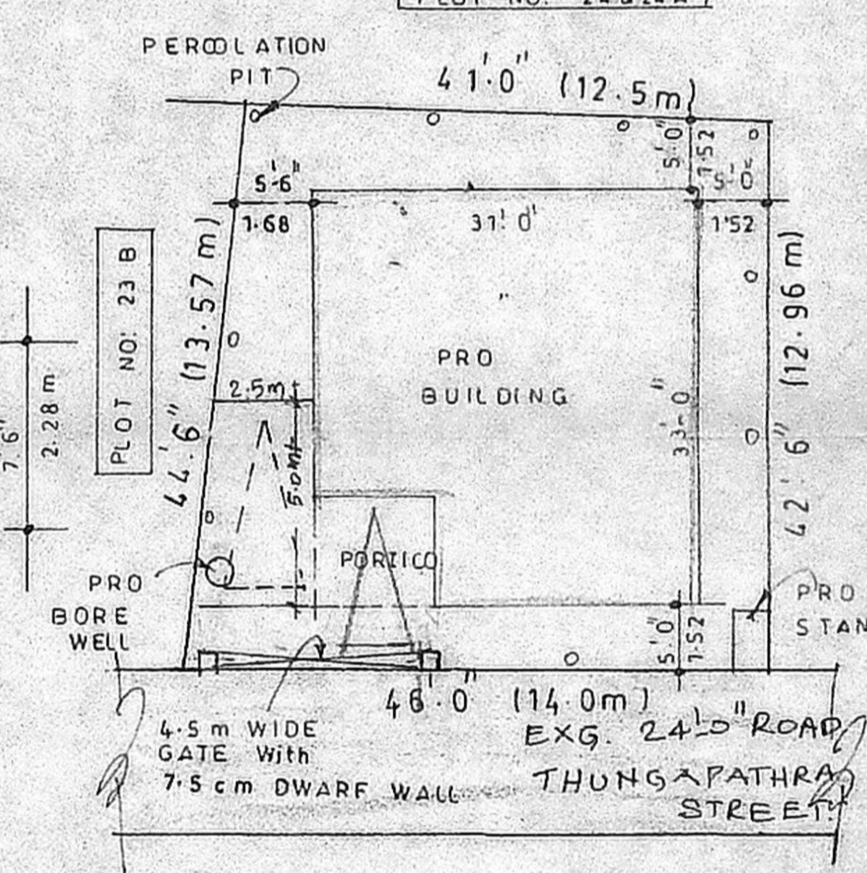

SCALE 1"=16'0" (1:200)

SITE PLAN.

PLAN SHOWING THE PRO. RESIDENTIAL BUILDING  
IN PLOT Nös 23 & 23 A BHARATH NAGAR  
SURVEY Nö 270/9pt., KEELKATTALAI VILLAGE  
TAMBARAM TALUK KANCHEEPURAM DISTRICT

AREA STATEMENT

PLOT AREA	: 1902 SFT	176.69 M <sup>2</sup>
PRO. G. FLOOR	: 1023 "	95.03 "
PRO. F. FLOOR	: 1023 "	95.03 "
HEAD ROOM	: 86 "	7.98 "
TOTAL AREA	: 2132 "	198.06 "
F. S. I	: 1.12	
COVERAGE	: 53%	

JOINERY DETAILS.

D DOOR	3'3" x 7'0"
D	3'0" x 7'0"
D	2'6" x 7'0"
W WINDOW	4'6" x 4'0"
W	3'0" x 4'0"
V VENTILATOR	2'6" x 2'0"

COLOUR INDEX

PROPOSED	
ROAD	
BOUNDARY	

*L. G. ...*  
OWNER

*B. Jamesh Shaiek Sulaiman, D.O.E.*  
Consulting Civil Engineer,  
Licensed Surveyor, Alandur Municipality,  
NEW INDIA PLANNERS,  
45-B, Medavakkam Main Road, (Upstairs)  
Puzhuthivakkam, Chennai-600 091.  
Phone: 2244557  
LICENSED SURVEYOR